

Residential Smart Wi-Fi Thermostat

PSP4272 Up to 4-heat / 2-cool with Humidity Control
OPTIONAL Wi-Fi and Local API with module

1 Specifications 2 Installation Instructions and Wiring 3 Installer Setup
4 Factory Defaults 5 Technician Setup & Calibration 6 Troubleshooting
7 Limited Warranty



WARNING

Follow Installation Instructions carefully. Disconnect Power to the Heater/Air Conditioner before removing the old thermostat and installing the new thermostat.

1 Specifications

- Geofencing for automatic Home and Away settings using the **ProStat+** app location services on your mobile device
- Choose 7-Day, 5/1/1 Day or 1-Day Programming
- 365-Day Vacation Programming (When Connected to **ProStat+** Web Portal)
- Setpoint Limiting
- Adjustable Timers & Deadbands Between Stages
- Adjustable Staging Turnoffs, Deenergize At Deadband or Keep Active Until Setpoint
- Can Be Used to Comply with 2016 Title 24, Part 6 Thermostat Requirements
- Programmable Fan Runs 5 - 60mins Per Hour with Adjustable Start/Stop Times
- Outdoor Sensor Ready With Hi/low Readouts for the Day
- Condensate Overflow Warning System
- Control To, or Monitor a 2nd Remote Sensor, Baby's Room or Game Room, etc.
- Choice of English, Spanish or French for Scrolling Display
- OEM-branded Equipment Badges Included

2 Installation Instructions

1 Remove and Replace the old thermostat

To install the thermostat properly, please follow these step by step instructions. If you are unsure about any of these steps, call a qualified technician for assistance.

- Installation tools: Small flat blade screwdriver, Phillips screwdriver, wire cutters and wire strippers.



- Make sure your Heater/Air Conditioner is working properly before beginning installation of the thermostat.
- Carefully unpack the thermostat. Save the screws, any brackets, and instructions.
- Turn off the power to the Heating/Air Conditioning system at the main fuse panel. Most residential systems have a separate breaker or switch for disconnecting power to the furnace.
- Remove the cover of the old thermostat. If it does not come off easily, check for screws.
- Loosen the screws holding the thermostat base or subbase to the wall and lift away.
- If you have a smart phone handy, take a photo of the wiring for future reference.
- Disconnect the wires from the old thermostat. Tape the ends of the wires as you disconnect them, and mark them with the letter of the terminal for easy reconnection to the new thermostat.
- Keep the old thermostat for reference purposes, until your new thermostat is functioning properly.

2 The ProStat+ Thermostat Backplate

To remove the thermostat backplate:

Gently separate the display from the base by pulling from the center.

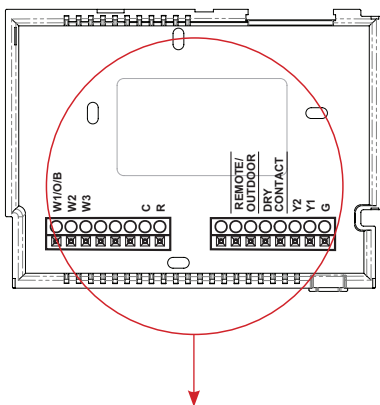

To remove the thermostat backplate from the wall: pry with screwdriver in either screw slot to remove back plate

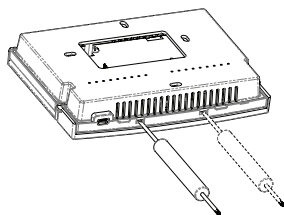

R	24 VAC return	C	24 VAC common
G	Fan relay	DRY CONTACT	FDD alerts, twist timer, etc.
W1/O/B	1st stage heat circuit or reversing valve	REMOTE SENSOR	Remote sensor connections
W2	2nd stage heat circuit*	OUTDOOR SENSOR	Outdoor sensor connections
W3	3rd stage heat circuit**		
Y1	1st stage compressor (Cool or Heat)		
Y2	2nd stage compressor (Cool or Heat)		

*3rd stage heat for heat pumps with two compressor stages

**4th stage heat for heat pumps with two compressor stages

IMPORTANT: This thermostat requires both R (24 VAC Return) and C (24 VAC Common) be connected to the backplate terminals.

3 Check Dip Switch

Ensure which switch is correct for your system. Dip switches are located on the back of the thermostat.

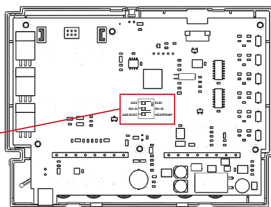
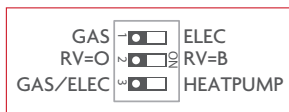

OR



1. When **GAS/ELEC** or **HEATPUMP** is set for **GAS/ELEC**: This switch (**GAS** or **ELEC**) controls how the thermostat will control the Fan (G) terminal in heating mode. When **GAS** is chosen, the thermostat will not energize the Fan (G) terminal in heating. When **ELEC** is chosen the thermostat will energize the fan in heating.

2. When **GAS/ELEC** or **HEATPUMP** is set for **HEATPUMP**: This switch (**GAS** or **ELEC**) defines the Aux Heat type. When **GAS** is chosen, the auxiliary heat will not be allowed to run during heat pump operation. When **ELEC** is chosen, up to two stages of auxiliary strip heat will be allowed to run.



OR



For Heat Pump Only

When the **GAS/ELEC** or **HEATPUMP** dip switch is configured for **HEATPUMP**, this dip switch (O or B) must be set to control the appropriate reversing valve. If **O** is chosen, the **W1/O/B** terminal will energize in cooling. If **B** is chosen, the **W1/O/B** terminal will energize in heating.



OR



This dip switch configures the thermostat to control a conventional gas/electric system or a heat pump. If your system is anything other than a heat pump, leave this switch set for **GAS/ELEC**.

4 Sample Wiring Diagrams

Conventional Heating and Cooling Systems

3 Wire, Heat Only

Residential & Commercial 1 Stage Heating with no Fan.

R 24VAC Power
C 24VAC Common
W1/O/B 1st Stage Heat



4 Wire, Cool Only

Residential & Commercial 1 Stage Cooling.

R 24VAC Power
C 24VAC Common
Y1 1st Stage Cool
G Fan



5 Wire, 1 Stage Cooling, 1 Stage Heat

Residential & Commercial 1 Stage Cooling, with 1 stage Gas Heat.

R 24VAC Power
C 24VAC Common
W1/O/B 1st Stage Heat
Y1 1st Stage Cool
G Fan



5 Wire, 1 Stage Cooling, 1 Stage Heat

Residential & Commercial 1 Stage Cooling, with 1 stage Electric Heat.

R 24VAC Power
C 24VAC Common
W1/O/B 1st Stage Heat
Y1 1st Stage Cool
G Fan



8 Wire, 2 Stage Cooling, 3 Stage Heat

Residential & Commercial 2 Stage Cooling, with 3 stage Gas Heat.

R 24VAC Power
C 24VAC Common
W1/O/B 1st Stage Heat
W2 2nd Stage Heat
W3 3rd Stage Heat
Y1 1st Stage Cool
Y2 2nd Stage Cool
G Fan



Heat Pump Systems

5 Wire, 1 Stage Cooling, 1 Stage Heat

Residential & Commercial Heat Pump with
O Reversing Valve

R 24VAC Power
C 24VAC Common
W1/O/B Reversing Valve
Y1 1st Stage Compressor
(Cool or Heat)
G Fan



6 Wire, 1 Stage Cooling, 2 Stage Heat

Residential & Commercial Heat Pump with
O Reversing Valve

R 24VAC Power
C 24VAC Common
W1/O/B Reversing Valve
Y1 1st Stage Compressor
(Cool or Heat)
W2 Aux Heat
G Fan



7 Wire, 2 Stage Cooling, 3 Stage Heat

Residential & Commercial Heat Pump with
O Reversing Valve.

R 24VAC Power
C 24VAC Common
W1/O/B Reversing Valve
W2 3rd Stage Heat
Y1 1st Stage Compressor
(Cool or Heat)
Y2 2nd Stage Compressor
(Cool or Heat)
G Fan

Setup Step 31 is set to 2
(Number of Compressor Stages)



8 Wire, 2 Stage Cooling, 4 Stage Heat

Residential & Commercial Heat Pump with
O Reversing Valve.

R 24VAC Power
C 24VAC Common
W1/O/B Reversing Valve
W2 3rd Stage Heat
W3 4th Stage Heat
Y1 1st Stage Compressor
(Cool or Heat)
Y2 2nd Stage Compressor
(Cool or Heat)
G Fan

Setup Step 31 is set to 2
(Number of Compressor Stages)



Note: When the unit goes into 4th stage heating, there is no 4th stage indicator, the display will still show 3rd stage.

Heat Pump Systems with Dual Fuel

5 Wire, 1 Stage Cooling, 1 Stage Heat

Residential & Commercial Heat Pump with
O Reversing Valve

R 24VAC Power
C 24VAC Common
W1/O/B Reversing Valve
Y1 1st Stage Compressor
(Cool or Heat)
G Fan



Dry Contact

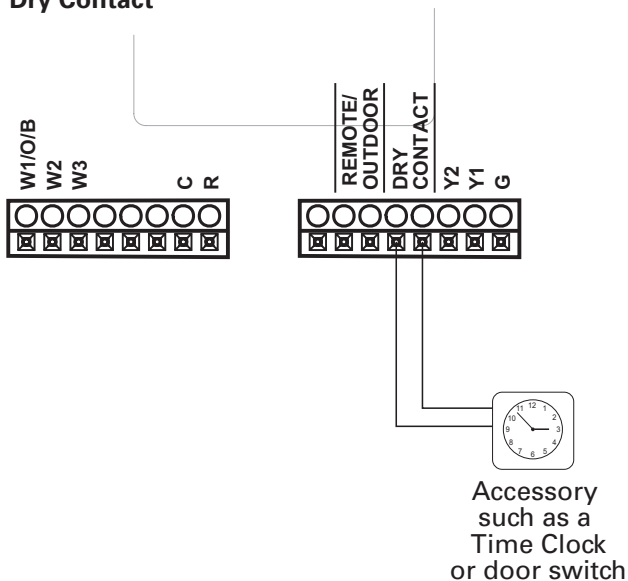

3 Installer Setup

Setup Step Table

See User Manual for steps 1 - 8

FD = Factory
Default Setting

Step#	Description	Pg#	Range	Df
1	Prog Mode		Non, 1 Day, 5/2 Day, 7 Day	7
2	Available Modes		Heat/Cool/Auto/Off, Heat/Cool/Off, Heat/Off, Cool/Off	Heat/Cool/Auto/Off
3	Backlight		On, Off	Off
4	Backlight Level		Off thru 7 levels of brightness	Level 5
5	Night Dimmer		On/Off	Off
6	Night Dimmer Brightness		Off thru 7 levels of brightness	2 (20%)
7	Night Dimmer Start Time		12A-12A	8:00P
8	Night Dimmer Stop Time		12A-12A	6:00A
9	Current Service Filter Runtime Hours		0-1999 Hours	0
10	Current Service Filter Calendar Days		0-720 Days	0
11	Current UV Lamp Calendar Days		0-720 Days	0
12	Set Service Filter Runtime Hours		0-1950 hours	0
13	Set Service Filter Calendar Days		0-720 Days	0
14	Set UV Lamp Calendar Days		0-720 Days	0
15	Language		English, Espanol, Francais	English
16	Scrolling Method		"L-R Slow, L-R Fast, Word L-R Slow, Word L-R Fast, Whole Word L Slow, Whole Word R Slow, Whole Word Ctr. Fast, Whole Word Ctr. Slow"	"Whole Words Center Fast"
17	Setpoint Limits		No, Use	No
18	Max Heat Setpoint		35 - 99 Degrees	74
19	Min Cool Setpoint		35 - 99 Degrees	70
20	Cycles Per Hour		No Limit, 2, 3, 4, 5, 6	6
21	Compressor Minimum Off Minutes		0, 3, 5 Minutes	5
22	Min. Heat/Cool Setpoint Difference		0 - 6 Degrees	2
23	Number of Heat Stages		0 - 3	2
24	Number of Cool Stages		0 - 2	1
25	Number Of Compressor Stages		1, 2	1
26	Number of Aux Stages		0, 1, 2	0
27	1st Stage Deadband		1 - 6 Degrees	2
28	2nd Stage Deadband		0 - 10 Degrees	2
29	3rd Stage Deadband		0 - 10 Degrees	2
30	4th Stage Deadband		0 - 10 Degrees	2
31	Minutes Between 1st and 2nd Stage		0 - 60 Minutes	2
32	Minutes Between 2nd and 3rd Stage		0 - 60 Minutes	2
33	Minutes Between 3rd and 4th Stage		0 - 60 Minutes	2
34	2nd Stage Turnoff Point		Deadband, Setpoint	Deadband
35	3rd Stage Turnoff Point		Deadband, Setpoint	Deadband

Step#	Description	Pg#	Range	Df
36	4th Stage Turnoff Point		Deadband, Setpoint	Deadband
37	Fan Program		On, Off	Off
38	Minutes of Fan Runtime		0-60	0
39	Fan Program Start Time		12:00A - 12:00A	7:00A
40	Fan Program Stop Time		12:00A - 12:00A	9:00A
41	Wired Sensor Type		Remote, Supply	Remote
42	Control to Temp Source		Thermostat, Wired Remote*, Wireless Remote, Average of Wireless Remotes, Average Thermostat and Wired Remote*, Average All Sensors. *Option only if prior step = "Remote"	Thermostat
43	Wireless Remote to Use		list of wifi sensors currently linked to thermostat. * This step only appears if prior step = "Wireless Remote"	first linked sensor in list
44	Fan Off Delay		0 - 120 Seconds	0
45	F/C		Fahrenheit (F), Celsius (C)	F
46	Comfort Recovery		On, Off	Off
47	Dry Contact Polarity		Open, Closed	Open
48	Dry Contact Use		Condensate, Vacation, FDD	Vacation
49	ProStat+ Web Portal		On, Off	On
50	Local API		On, Off	Off
51	ADR		On, Off	On
52	Price Dependant Action		Observe Setpoint Offset, Observe Static Setpoints	Observe set- point offsets
53	Event Max Cool Setpoint		65 - 90	90
54	Event Min Heat Setpoint		50 - 85	50
55	Static Cool Setpoint		65 - 85	82
56	Static Heat Setpoint		65 - 85	60
57	Cool Setpoint Offset		1 to 10	4
58	Heat Setpoint Offset		-1 to -10	-4
59	Press Fan To Clear All Messages			

How to Change Settings in the Setup Screens

To enter Advanced Setup, press the **SETUP** button, then press **MODE**. Use the **WARMER** or **COOLER** buttons to adjust the value of your selection. Press **MODE** to advance to the next setup step. Press **SETUP** again to leave the setup screens.



These setup steps allow the user to monitor equipment runtimes and program service alerts. Service alerts are displayed in the scrolling marquee.



Press and hold **FAN** to clear service alert messages from the scrolling marquee.

Runtime Alerts & Reset (Setup Steps 9-14)

Current Service Filter Runtime Hours (Setup Step 9) - This counter keeps track of the number of hours of fan runtime in the Heating mode, Cooling mode, and in stand alone Fan operation. Press **FAN** to reset.

Current Service Filter Calendar Days (Setup Step 10) - This counter displays the total number of calendar days that have elapsed since the counter was reset to help the user track filter usage. Press **FAN** to reset.

Set Service Filter Runtime Hours (Setup Step 12) - This timer allows the user to specify the number of hours the fan will run before the "Replace Filter" alert will be displayed. Press **COOLER** continuously until 0 is displayed to disable this alert.

Set Service Filter Calendar Days (Setup Step 13) - This timer allows the user to specify the number of calendar days that will elapse before the "Replace Filter" alert will be displayed. Press **COOLER** continuously until 0 is displayed to disable this feature.

UV Lamp Runtime (Setup Steps 11, 14)

Current UV Lamp Calendar Days (Setup Step 11) - This counter displays the total number of calendar days that have elapsed since last reset to help the user track UV lamp runtime. Press **FAN** to reset.

Set UV Lamp Calendar Days (Setup Step 14) - This timer allows the user to specify the number of calendar days the UV Lamp will operate before the "Replace UV Lamp" alert will be displayed. Press **COOLER** continuously until 0 appears to disable this alert.

Scrolling Display (Setup Steps 15, 16)

Language (Setup Step 15) - Setup step instructions on the scrolling display can be set for English, Spanish, or French.

Scrolling Display Method (Setup Step 16) - This option allows the user to choose how the scrolling text is displayed. Options are:

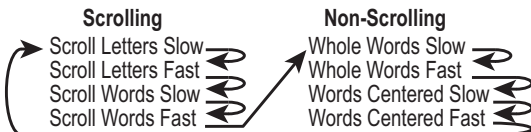

Setpoint Limits (Setup Steps 17-19)

Setpoint Limits (Setup Step 17) - When this feature is at any setting other than NO SETPOINT LIMITS the heat and cool setpoints can be restricted to preset levels, set in steps 23 and 24. This feature allows the user to set 3 different levels of security: (0 - 3).

No Setpoint Limits (0) - When this level is selected, no restrictions are activated.

Use Setpoint Limits (1) - When this level is selected, the heat and cool setpoints can be restricted to preset levels, set in setup steps 18 and 19.

Maximum Heat Setpoint (Setup Step 18) - (35° - 99°).

Minimum Cool Setpoint (Setup Step 19) - (35° - 99°).

Force Program Mode (2) - When this level is selected, the heat and cool setpoints can be restricted to preset levels, set in setup steps 18 and 19 and the thermostat is locked into the current mode and the PROGRAM OFF | RUN and FAN buttons are locked out.

Setpoints Frozen (3) - When this level is selected, the heat and cool setpoints, the current mode, the FAN button and the PROGRAM OFF | RUN and FAN buttons are locked.

Staging & Cycle Timers (Setup Steps 20-26)

Cycles Per Hour (Setup Step 20) - The Cycles Per Hour setting may limit the number of times per hour your HVAC unit may energize. For example, at a setting of 6 cycles per hour the HVAC unit will only be allowed to energize once every 10 minutes. The Cycles Per Hour limit may be overridden and reset by pressing the WARMER or COOLER buttons on the thermostat. Settings are No Limit, 2, 3, 4, 5, or 6.

Compressor Minimum Off Minutes (Setup Step 21) - This feature allows the user to set a minimum off time for the compressor. Settings are 5 mins., 3 mins., or 0 mins.

Minimum Heat/Cool Setpoint Difference (Setup Step 22) - This feature allows the user to set the minimum gap between Heat and Cool setpoints in AUTO mode. Select from 0 to 6. If setup step 2 is not set for AUTO-CHANGEOVER, this step will not appear.

Number of Heat Stages (Setup Step 23) - This setting assures proper stage callouts on the thermostat display for non-heat pump applications.

Number of Cool Stages (Setup Step 24) - This setting assures proper stage callouts on the thermostat display for non-heat pump applications.

Number of Compressor Stages (Setup Step 25) - This feature is for heat pump applications only. This feature allows the thermostat to control 1 or 2 compressor stages when configured for heat pump.

Number of Aux Stages (Setup Step 26) - This feature is for heat pump applications only. This feature allows for proper Aux Heat Staging. (0-2 stages)

Deadband Settings (Setup Steps 27-36, 46)

The Deadband is the number of degrees or minutes that the thermostat waits before it initiates each stage of heating or cooling.

1st Stage Deadband (Setup Step 27) - Specifies the minimum temperature difference between the room temperature and the desired setpoint before the first stage of heating or cooling is allowed to turn on (1 - 6 degrees). For example, if the heat setpoint is 68° and the 1st Stage deadband is set to 2 degrees, the room temperature will need to fall to 66° before the heat turns on.

2nd Stage Deadband (Setup Step 28) - Specifies the additional minimum temperature difference after the first stage turns on before the second stage is activated. (0° - 10°)

3rd Stage Deadband (Setup Step 29) - Specifies the additional minimum temperature difference after the second stage turns on before the third stage is activated. (0° - 10°)

4th Stage Deadband (Setup Step 30) - (Two Stage heat pump only) - Specifies the additional minimum temperature difference after the third stage turns on before the final stage of strip heat is activated (0° - 10°).

Minutes Between 1st and 2nd Stage (Setup Step 31) - Specifies the minimum time (in minutes) after the first stage turns on before the second stage can turn on. (0 - 60)

Minutes Between 2nd and 3rd Stage (Setup Step 32) - Specifies the minimum time (in minutes) after the second stage turns on before the third stage can turn on. (0 - 60)

Minutes Between 3rd and 4th Stage (Setup Step 33) - Specifies the minimum time (in minutes) after the third stage turns on before the final stage can turn on. (0 - 60)

Second Stage Turnoff Point (Setup Step 34) - Specifies whether second stage will turn off at first stage deadband or remain on until the room temperature demand is satisfied. Choose between Deadband or Setpoint.

Third Stage Turnoff Point (Setup Step 35) - Specifies whether third stage will turn off at second stage deadband or remain on until the room temperature demand is satisfied. Choose between Deadband or Setpoint.

Fourth Stage Turnoff Point (Setup Step 36) - Specifies whether fourth stage will turn off at third stage deadband or remain on until the room temperature demand is satisfied. Choose between Deadband or Setpoint.

Comfort Recovery (Setup Step 46) - With Comfort Recovery on, the thermostat will attempt to reach the Morning setpoint temperature at the exact time programmed into the thermostat. Comfort Recovery, only works when the thermostat enters the Morning mode from the Night mode. For example, if the Morning program is set for 6am at 72°F heating and 75°F cooling, the thermostat will turn the system on before 6am in an effort to bring the temperature to its correct setting at exactly 6am. The thermostat learns from experience, so please allow 4-8 days after a program change or after initial installation to give Comfort Recovery time to adjust. If used with a heat pump, electric strip heat will be disabled while Comfort Recovery is active.

Fan Operation (Setup Steps 37-40, 44)

Fan Program (Setup Step 37) - This feature allows the fan to be programmed to turn on automatically for a specified amount of time during the day. If this feature is set to ON, the next three steps will appear.

Minutes of Fan Runtime Per Hour (Setup Step 38) - This setting specifies the number of minutes (0 - 60, in increments of 5) that the fan will run at the top of each hour.

Fan Program Start Time (Setup Step 39) - This setting specifies the hour of each day when the programmable fan feature will start.

Fan Program Stop Time (Setup Step 40) - This setting specifies the hour of each day when the programmable fan feature will stop. NOTE: Setting the Stop Hour equal to the Start Hour will cause the fan to run 24 hours a day.

Fan Off Delay in Seconds (Setup Step 44) - This feature allows the user to increase the cooling or electric strip heating efficiency of the system. The thermostat may be programmed to continue running the fan after a call for cooling or electric strip heating has been satisfied. This delay can be set for 0, 30, 60, 90, or 120 seconds. If set to 0, the fan will not run after a call for cooling or electric strip heating has been satisfied.

Remote Sensor Operation (Setup Steps 41-43, 45)

Wired Sensor Type (Setup Step 41) - Specifies the use of the connected, wired sensor. The choices are: Remote or Supply. The remote option allows control to the sensor, the supply is for monitor only.

Control To Temp Source (Setup Step 42) - This feature allows the user to specify which temperature sensor source the thermostat will use to measure room temperature.

Thermostat: Uses the internal thermostat sensor only.

Remote Sensor: Uses wireless or wired sensors only.

Average of Remote Sensor and Thermostat: Averages the temperatures of the remote sensor(s) and the thermostat.

Wireless Remote To Use (setup step 43) - Specifies which single wireless remote sensor is to be used for control. This step only appears when prior step setting is Wireless Remote.

Fahrenheit or Celsius (Setup Step 45) - This feature allows the thermostat to display temperature in Fahrenheit or Celsius.

NOTE: If a remote sensor is being used, the degree icon on the large room temperature display will blink.

Dry Contact Operation (Setup Steps 47, 48)

Dry Contact Polarity (Setup Step 47)

Open (Normally Open) - The dry contact is open until the connected device closes the circuit.



'Idle'



'Active'

Closed (Normally Closed) - The dry contact is closed until the connected device opens the circuit.



'Idle'



'Active'

Condensate Dry Contact Use (Setup Step 48)

If selected when the dry contact is active, the thermostat will lockout the compressor terminal(s) and **CONDENSATE PAN OVERFLOW** will appear on the display.

VACATION - The HOME/AWAY feature allows the thermostat to use temporary, energy saving settings without having to change regular programming. Vacation setup/programming at the local thermostat is limited to the number of days employing Home/Away settings. When the optional Wi-Fi module is detected in the thermostat, local Vacation programming is not allowed. In this case Vacation setup and programming is accomplished with the **ProStat+** web portal. The **ProStat+** web portal gives the user extensive control over Vacation settings.

Press the Vacation button to enter Vacation/Away programming (no Wi-Fi Module detected).

If there is not a period active:

Use the Warmer and Cooler buttons to choose the number of days desired to run the Vacation feature. To confirm your settings and advance to the next step, press the Vacation button again. Choose the desired Vacation Cool set point. Press Vacation. Then choose the desired Vacation Heat set point. Press Holiday to return to the main screen.

FDD - If FDD is selected when the dry contact is active, the scrolling display will read EQUIPMENT FAULT. This error message will disappear when the Dry Contact is idle.

REMOTE - No action is taken at the thermostat. The dry contact status is simply communicated to the **ProStat+** web portal.

Web Portal, API, & ADR Operation (Setup Steps 49-58)

ProStat+ Web Portal (Setup Step 49) - If set to **ON**, the thermostat may communicate and receive data from the **ProStat+** web portal.

Local API (Setup Step 50) - Turning the local API to **ON** allows 3rd party software to interface with your thermostat such as a building automation system.

ADR Operation (Setup Steps 51-58)

ADR (Setup Step 51) - Controls whether you want the thermostat to respond to signals from a utility provider. Select **ON** to allow this and to have steps 76-82 appear.

Price Dependent Action (Setup Step 52) - Allows the user to determine what action is taken when the price rises above the set threshold. Note that the threshold price is only adjustable via Skyport.

Event Max Cool Setpoint (Setup Step 53)

Event Min Heat Setpoint (Setup Step 54)

Specifies the range of allowable setpoint adjustments to be enforced when any ADR signal has been received from the utility. Since you might be paying more for energy while an event is active, you can impose tighter limits on setpoint ranges that are only enforced during the event.

Static Cool Setpoint (Setup Step 55)

Static Heat Setpoint (Setup Step 56)

Specifies the setpoints that will come into use during an event when the PRICE DEPENDENT ACTION is set to OBSERVE STATIC SETPOINT

Cool Setpoint Offset (Setup Step 57)

Heat Setpoint Offset (Setup Step 58)

Specifies how much the current setpoints in effect prior to an event will be altered during an event when the PRICE DEPENDENT ACTION is set to OBSERVE SETPOINT OFFSETS. The heat setpoint can be automatically lowered by 1 to 10 degrees while the cool setpoint can be automatically raised by 1 to 10 degrees.

DISPLAY INDICATIONS WHEN AN ADR EVENT IS HAPPENING

After setting your desired values for use during an ADR event, the scrolling display will give a little information when an event is pending or active. For instance, when an ADR event has been sent to your thermostat, you might see ADR STARTS at 4:15 to notify you of a pending event. Once active, you might see ADR STOPS at 5:30. If you have configured a threshold for cost of energy past which you want to trigger an event, you will see PRICING EVENT on the display. When an event is active, you can press any of COOLER, WARMER or

MODE buttons, followed by the WARMER to opt out of the event.

Press Fan To Clear All Messages (Setup Step 59)

This feature allows the user to clear all current error messages from the display.

Locking/Unlocking the Keypad

To prevent unauthorized use of the thermostat, the front panel buttons may be disabled. To disable, or 'lock' the keypad, press and hold the MODE button. While holding the MODE button, press the WARMER and COOLER buttons together, and the  icon will appear on the display.

To **unlock** the keypad, press and hold the MODE button. While holding the MODE button, press the WARMER and COOLER buttons together, and the  icon will disappear from the display.

4 Factory Defaults

If, for any reason, you desire to return all the stored settings back to the factory default settings, follow the instructions below.

WARNING: This will reset all Time Period and Advanced Programming to the default settings. Any information entered prior to this reset will be permanently lost.

- 1 Press and hold **SETUP** for 10 seconds. All icons will appear on the display. Keep pressing the **SETUP** button until you see this screen.

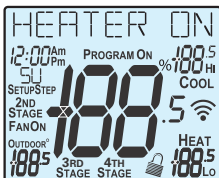

- 2 After all the icons appear, release **SETUP**. Press and hold **FAN** for 5 seconds. **DEFAULTS** will appear on the display.

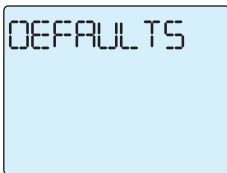

- 3 After **DEFAULTS** appears, release **FAN**. Press **SETUP** to return to normal operation.

5 Technician Setup & Calibration

To enter Technician Setup, press and hold the SETUP button for 10 seconds. After all the icons appear, press MODE. The version number of the thermostat will appear in the scrolling text. Press MODE to advance to the next step. Use the WARMER or COOLER buttons to adjust the value of your selection. To leave Technician Setup, press SETUP.

Hold for 10 seconds



All icons appear

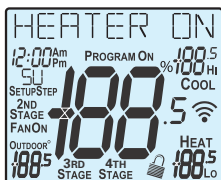

Press MODE to advance through the setup steps



Press WARMER or COOLER to adjust the selection



Technician Setup is for diagnostic and testing purposes and is intended for use by a qualified technician. See next page for more detailed instructions.

Technician Setup contains the following options:

- View the version number of the thermostat.
- View the jumper setting of J1 (Gas/Electric or Heat Pump), J2 (Reversing Valve: RV=0 or RV=B), and J3 (Fan: Gas or Electric) jumpers located on the back of the thermostat. (Remove thermostat from backplate for access)
- View the state of the Dry Contact and Fault terminals.
- Turn on equipment outputs for testing.
- Calibrate thermostat and remote sensors.

To enter Technician Setup, press and hold the SETUP button for 10 seconds until all the icons appear. Follow the next steps to view settings and test equipment.

1. Press MODE to view the version numbers of the thermostat.
2. Press MODE again to view the jumper settings and current state of the Dry Contact terminal.
3. Press MODE again and the scrolling display will read "TURN ON EQUIPMENT?"
Press WARMER for Yes or COOLER for No.

If Yes is chosen, press WARMER to turn on heat or COOLER to turn on Cooling.
The scrolling display will read "NOTHING ON." Next:

Press WARMER to turn on and cycle up through the heating stages.
Press COOLER to turn the heating stages off. Press MODE to exit.

Press COOLER to turn on and cycle down through the cooling stages.
Press WARMER to turn the cooling stages off. Press MODE to exit.

4. Press MODE until "CALIBRATE SENSORS?" appears on the scrolling display.
Press WARMER for Yes or COOLER for No. Press MODE to select which sensor to calibrate. Use WARMER or COOLER to modify your selection.

Press MODE to exit.

To exit Technician Setup at any time, press the SETUP button. Technician Setup will automatically exit after 10 minutes if no buttons are pressed.

6 Troubleshooting

- **SYMPTOM:** The air conditioning does not attempt to turn on.
CAUSE: The compressor timer lockout may prevent the air conditioner from turning on for a period of time.
REMEDY: Consult the manual Setup section to defeat the Cycles Per Hour.
- **SYMPTOM:** The display is blank.
CAUSE: Lack of proper power.
REMEDY: Make sure the power is on to the furnace and that you have 24vac between **R & C**.
- **SYMPTOM:** The air conditioning does not attempt to turn on.
CAUSE: The cooling setpoint is set too high.
REMEDY: Lower the cooling setpoint or lower the cooling setpoint limit.
See Setpoint Limits.
- **SYMPTOM:** The heating does not attempt to turn on.
CAUSE: The heating setpoint is set too low.
REMEDY: Raise the heating setpoint or raise the heating setpoint limit.
See Setpoint Limits.
- **SYMPTOM:** When controlling a residential heat pump, and asking for cooling, the heat comes on.
CAUSE: The thermostat reversing valve jumper is set for “**B**”.
REMEDY: Set the reversing valve jumper for “**O**”.
- **SYMPTOM:** When calling for cooling, both the heat and cool come on.
CAUSE: The thermostat equipment jumper is configured for “**HP**” and the HVAC unit is a Gas/Electric.
REMEDY: Set the equipment jumper for “**Gas/Elec**”.
- **SYMPTOM:** When the Program button is pressed, the display reads “**DISABLED**”.
CAUSE: Program mode is set to “**NON PROGRAM**”.
REMEDY: Set Program Mode (Setup 1) to **1, 5/2, or 7 Day**.
See Selecting Your Program Mode.

7 Limited Warranty

PSP Series - Thermostat Models: PSP1100, PSP1152, PSP2100, PSP2152, PSP2270, PSP2270C, PSP2111, PSP4272, PSP4273, PSP4271C, PSP4272C, PSP4272RT, PSP4273RT, PSP4272CT, PSP4273CT

Who Is Providing The Warranty?

This warranty is provided to you by Goodman Manufacturing Company, L.P. ("Goodman"), which warrants all parts of this thermostat ("control"), as described below.

To What Type Of Installations Does This Warranty Apply?

This warranty applies to controls installed in owner-occupied residences.

What Units Does This Warranty Not Cover?

This warranty does not apply to:

- Controls that are ordered over the Internet, by telephone, or by other electronic means unless the unit is installed by a dealer adhering to all applicable federal, state, and local codes, policies, and licensing requirements.
- Controls that are installed outside the United States, its territories, or Canada.
- Controls that are installed in buildings other than owner-occupied residences, such as non-residential buildings or residences not occupied by the owner.

What Problems Does This Warranty Cover?

This warranty covers defects in materials and workmanship that appear under normal use and maintenance.

Other Warranties

This warranty is in lieu of all other express warranties. ANY IMPLIED WARRANTIES BY GOODMAN, INCLUDING BUT NOT LIMITED TO WARRANTIES OF MERCHANTABILITY AND FITNESS FOR PARTICULAR PURPOSE, ARE LIMITED TO THE DURATION OF THIS WARRANTY. NO AFFILIATE OF GOODMAN GIVES ANY EXPRESS OR IMPLIED WARRANTY, INCLUDING BUT NOT LIMITED TO WARRANTIES OF MERCHANTABILITY AND FITNESS FOR PARTICULAR PURPOSE, ON THIS UNIT. Some states and provinces do not allow the exclusion of express warranties and/or limitations on how long an implied warranty lasts, so the above exclusion and/or limitation may not apply to you.

For further information about this warranty contact Consumer Affairs at (877) 254-4729 or by mail to 19001 Kermier Rd, Waller, Texas 77484

What Problems Does This Warranty Not Cover?

Goodman is not responsible for:

- Damage or repairs required as a consequence of faulty installation or application. • Damage as a result of floods, fires, winds, lightning, accidents, corrosive atmosphere, or other conditions beyond Goodman's control.
- Damage or the need for repairs arising from the use of components or accessories not compatible with this control.
- Normal maintenance as described in the installation and operating manual.
- Parts or accessories not supplied or designated by the manufacturer.
- Damage or the need for repairs resulting from any improper use, maintenance, operation, or servicing.
- Damage or failure of the control due to interruption in electrical service or inadequate electrical service.
- Any damage caused by frozen or broken water pipes in the event of equipment failure.
- Changes in the appearance of the control that do not affect its performance.
- Replacement of fuses and replacement or resetting of circuit breakers.

When Does Warranty Coverage Begin?

Warranty coverage begins on the "installation date." The installation date is one of two dates depending on the circumstances of purchase:

- (1) For controls installed in a newly constructed residence, the installation date is the date the owner purchases the residence from the builder.
- (2) For controls installed in existing residences, the installation date is the date that the control is originally installed.

- (3) For products on which a manufacture date is indicated, if the date the owner purchases the residence from the builder or the date the product is originally installed cannot be verified, the installation date is three months after the manufacture date.
- (4) For products on which a manufacture date is not indicated, if the date the owner purchases the residence from the builder or the date the product is originally installed cannot be verified, the installation date is the date the condensing unit to which the product is paired was originally installed.

How Long Does Warranty Coverage Last?

The warranty lasts for a period up to 1 YEAR. The warranty period does not continue after the control is removed from the location where it was originally installed. The replacement of a part under this warranty does not extend the warranty period. In other words, Goodman warrants a replacement control only for the period remaining in the applicable warranty that commenced on the installation date.

What Will Goodman Do To Correct Problems?

Goodman will furnish a replacement control, without charge for the control only, to replace any control that is found to be defective due to workmanship or materials under normal use and maintenance. Furnishing of the replacement control is Goodman's only responsibility under this warranty and the furnishing of the replacement control is the owner's only remedy.

THE OWNER AGREES THAT THESE REMEDIES ARE THE OWNER'S EXCLUSIVE REMEDIES FOR BREACH OF ALL WARRANTIES, EXPRESS OR IMPLIED.

What Won't Goodman Do To Correct Problems?

Goodman will not pay for:

- Labor, freight, or any other cost associated with the service, repair, or operation of the control.
- Electricity or fuel costs, or increases in electricity or fuel costs, for any reason, including additional or unusual use of supplemental electric heat.
- Lodging or transportation charges.

WHETHER ANY CLAIM IS BASED ON NEGLIGENCE OR OTHER TORT, BREACH OF WARRANTY OR OTHER BREACH OF CONTRACT, OR ANY OTHER THEORY, NEITHER GOODMAN NOR ANY OF ITS AFFILIATES SHALL IN ANY EVENT BE LIABLE FOR INCIDENTAL OR CONSEQUENTIAL DAMAGES, INCLUDING BUT

NOT LIMITED TO LOST PROFITS, LOSS OF USE OF A CONTROL, EXTRA UTILITY EXPENSES, OR DAMAGES TO PROPERTY.

Some states and provinces do not allow the exclusion or limitation of incidental or consequential damages, so the above exclusion may not apply to you.

How Can The Owner Receive Warranty Service?

If there is a problem with the control, contact a licensed contractor.

To receive a replacement control, a licensed contractor must bring the defective control to a Goodman heating and air conditioning products distributor.

For more information about the warranty, contact Consumer Affairs at 877-254-4729 or write to Consumer Affairs, 19001 Kernier Rd, Waller, TX 77484.

This warranty gives you specific legal rights, and you may also have other rights that vary from state to state or province to province.

Quebec Residents

The arbitration provisions of this warranty shall not apply to residents of Quebec.

Non-Owner Occupied Warranty

Products installed in non-residential buildings or in residences not occupied by the owner are warranted for a period of 1 YEAR. **THIS WARRANTY IS PROVIDED IN LIEU OF ANY OTHER WARRANTIES, WHETHER BY GOODMAN OR ANY OF ITS AFFILIATES, EXPRESS OR IMPLIED, INCLUDING ANY IMPLIED WARRANTY OF MERCHANTABILITY OR FITNESS FOR A PARTICULAR PURPOSE.** Subject to the additional limitations set forth in this paragraph, all other provisions of the Limited Warranty apply to products installed in non-residential buildings or in residences not occupied by the owner.

Where Can Any Legal Remedies Be Pursued?

ARBITRATION CLAUSE. IMPORTANT. PLEASE REVIEW THIS ARBITRATION CLAUSE. IT AFFECTS YOUR LEGAL RIGHTS.

1. **Parties:** This arbitration clause affects your rights against Goodman and any of its affiliates or employees or agents, successors, or assigns, all of whom together are referred to below as "we" or "us" for ease of reference.
2. **ARBITRATION REQUIREMENT: EXCEPT AS STATED BELOW, ANY DISPUTE BETWEEN YOU AND ANY OF US SHALL BE DECIDED BY NEUTRAL, BINDING ARBITRATION RATHER THAN IN COURT OR BY JURY TRIAL.** "Dispute" will be given the broadest possible meaning allowable by law. It includes any dispute, claim, or controversy arising from or relating to your purchase

of this control, any warranty upon the unit, or the unit's condition. It also includes determination of the scope or applicability of this Arbitration Clause. The arbitration requirement applies to claims in contract and tort, pursuant to statute, or otherwise.

3. CLASS-ARBITRATION WAIVER: ARBITRATION IS HANDLED ON AN INDIVIDUAL BASIS. IF A DISPUTE IS ARBITRATED, YOU AND WE EXPRESSLY WAIVE ANY RIGHT TO PARTICIPATE AS A CLASS REPRESENTATIVE OR CLASS MEMBER ON ANY CLASS CLAIM YOU MAY HAVE AGAINST US OR WE AGAINST YOU, OR AS A PRIVATE ATTORNEY GENERAL OR IN ANY OTHER REPRESENTATIVE CAPACITY. YOU AND WE ALSO WAIVE ANY RIGHT TO CLASS ARBITRATION OR ANY CONSOLIDATION OF INDIVIDUAL ARBITRATIONS.

4. Discovery and Other Rights: Discovery and rights to appeal in arbitration are generally more limited than in a lawsuit. This applies to both you and us. Other rights that you or we would have in court may not be available in arbitration. Please read this Arbitration Clause and consult the rules of the arbitration organizations listed below for more information.

5. SMALL CLAIMS COURT OPTION: YOU MAY CHOOSE TO LITIGATE ANY DISPUTE BETWEEN YOU AND ANY OF US IN SMALL CLAIMS COURT, RATHER THAN IN ARBITRATION, IF THE DISPUTE MEETS ALL REQUIREMENTS TO BE HEARD IN SMALL CLAIMS COURT.

6. Governing Law: For residents of the United States, the procedures and effect of the arbitration will be governed by the Federal Arbitration Act (9 U.S.C. § 1 et seq.) rather than by state law concerning arbitration. For residents of Canada, the procedures and effect of the arbitration will be governed by the applicable arbitration law of the province in which you purchased your control. The law governing your substantive warranty rights and other claims will be the law of the state or province in which you purchased your control. Any court having jurisdiction may enter judgment on the arbitration award.

7. Rules of the Arbitration: If the amount in controversy is less than \$250,000, the arbitration will be decided by a single arbitrator. If the amount in controversy is greater than or equal to \$250,000, the arbitration will be decided by a panel of three arbitrators. The arbitrator(s) will be chosen pursuant to the rules of the administering arbitration organization. United States residents may choose the American Arbitration Association (1633 Broadway, 10th Floor, New York, NY 10019, www.adr.org), JAMS (1920 Main Street, Ste. 300, Irvine, CA

92614, www.jamsadr.com), or, subject to our approval, any other arbitration organization. In addition, Canadian residents may choose the ADR Institute of Canada (234 Eglinton Ave. East, Suite 405, Toronto, Ontario, M4P 1K5, www.amic.org). These organizations' rules can be obtained by contacting the organization or visiting its website. If the chosen arbitration organization's rules conflict with this Arbitration Clause, the provisions of this Arbitration Clause control. The award of the arbitrator(s) shall be final and binding on all parties.

8. Location of the Arbitration Hearing: Unless applicable law provides otherwise, the arbitration hearing for United States residents will be conducted in the federal judicial district in which you reside or, for Canadian residents, in the province in which you reside.

9. Costs of the Arbitration: Each party is responsible for its own attorney, expert, and other fees unless applicable law requires otherwise. Goodman will pay your share of the fees charged by the arbitration organization and arbitrator(s) beyond the first \$200. Where permissible by law, you may be required to reimburse Goodman for the fees of the arbitration organization and arbitrator(s) in whole or in part by decision of the arbitrator(s) at the discretion of the arbitrator(s).

10. Survival and Enforceability of this Arbitration Clause:

This Arbitration Clause shall survive the expiration or termination, or any transfer, of the warranty on your control. If any part of this Arbitration Clause, except waivers of class-action rights, is found to be unenforceable for any reason, the remainder of this clause and the warranty shall remain enforceable. If, in a case in which class-action allegations have been made, the waiver of class-action rights under this warranty is found to be unenforceable with respect to any part of the dispute, the parts of the dispute as to which the waiver of class-action rights have been found unenforceable will be severed and will proceed in court without reference or application of this Arbitration Clause. Any remaining parts will proceed in arbitration.



Part No. PWCSTATPLUS



Innovation, Science and Economic Development Canada
ICES-003 Compliance Label: CAN ICES-3 (B)/NM8-3(B)

PROSTAT⁺
OEM SERIES

rev. 2 06/09/2021 88-1483